



PROVINCIA DI VENEZIA

Assessorato alla Mobilità e Trasporti

CORSO DI EDUCAZIONE ALLA SICUREZZA STRADALE

TESTO PER LA SCUOLA MATERNA

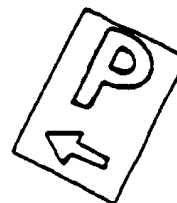
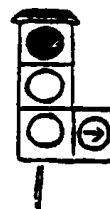
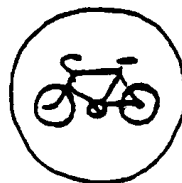

COGNOME _____ NOME _____ CLASSE _____

DISEGNO LA MIA STRADA

a cura di: Luciano Marini, Daniele Masiero, Dino Sabbadin e Lucia Tagliapietra

II° ristampa – marzo 2000



PROVINCIA DI VENEZIA

Assessorato alla Mobilità e Trasporti

Presenta

CORSO DI EDUCAZIONE ALLA SICUREZZA STRADALE ALUNNI DI SCUOLA MATERNA

SOMMARIO

Le forme dei segnali	pag. 2
La strada	" 8
Uso del marciapiede: destra e sinistra	" 10
Il pedone	" 12
Attraversamento della strada	" 14
Il semaforo pedonale	" 16
Il vigile	" 17
I gesti del vigile	" 18
Conosci i tuoi segnali	" 19
Attività	" 20
Scheda: segnali da ritagliare	" 25
Avviso ai genitori	" 26

LE FORME DEI SEGNALI

OBIETTIVO: percezione e ricostruzione delle forme dei segnali

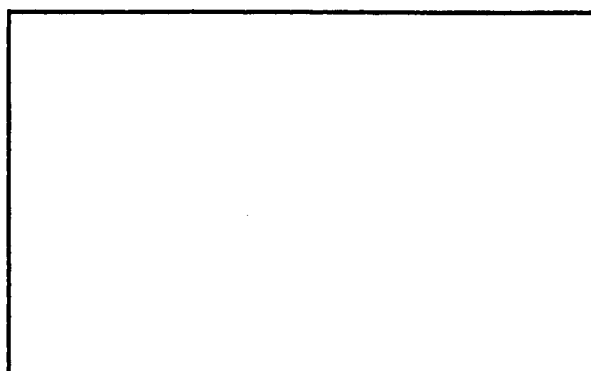
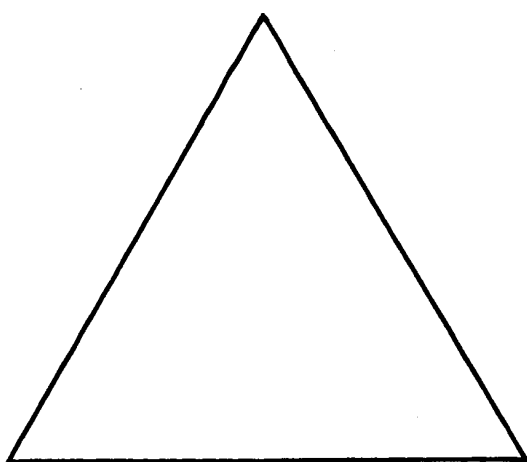
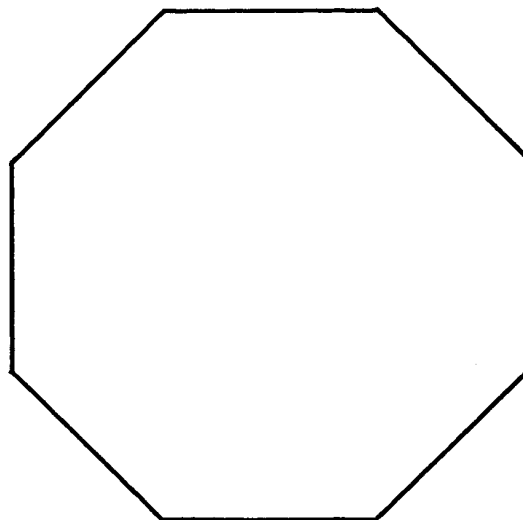
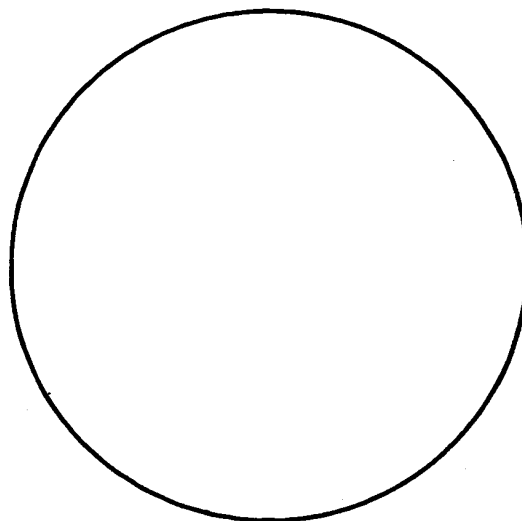
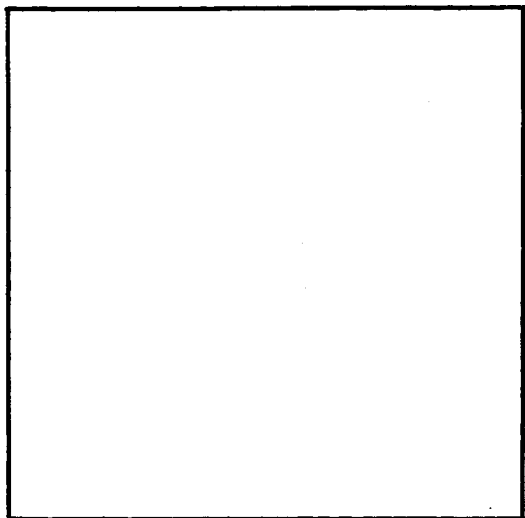

ATTIVITÀ: il bambino ricomponne le forme ritagliando le figure a pag. 3

ATTIVITÀ: il bambino ritaglia le forme tratteggiate e le incolla sulla forma corrispondente a pag.2

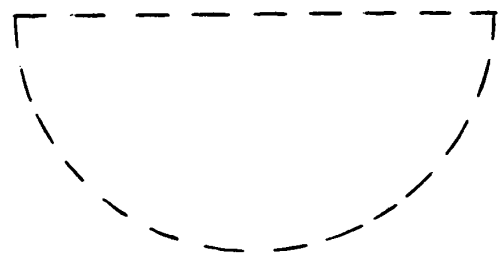
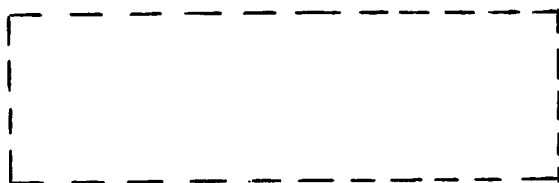
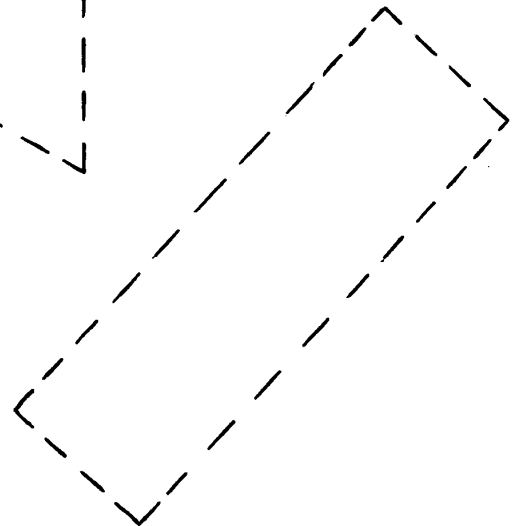
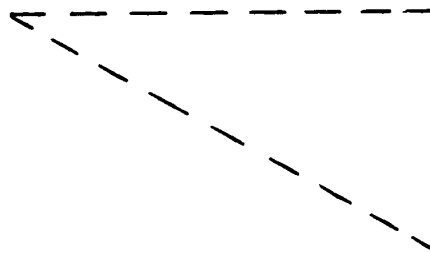
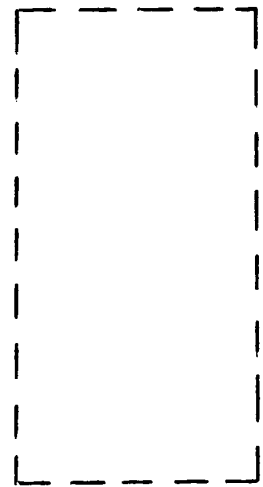
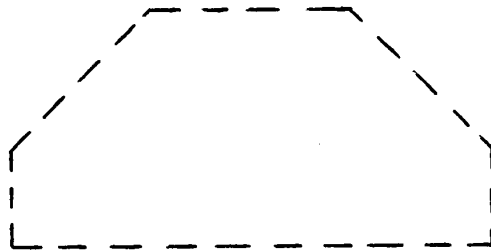
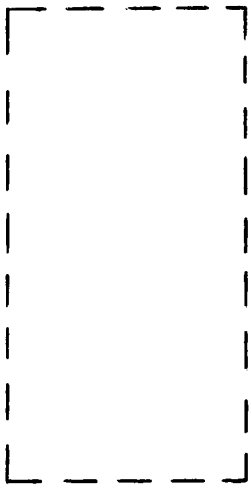
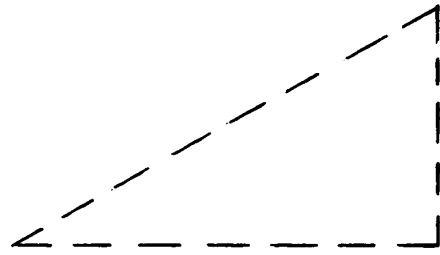
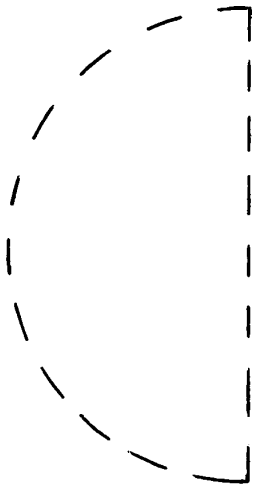

OBIETTIVO: saper identificare, discriminare, abbinare colori e forme

ATTIVITÀ: il bambino colora il cerchio (blu), il quadrato (verde), il triangolo (rosso),
l'ottagono (marrone), il rettangolo (giallo)

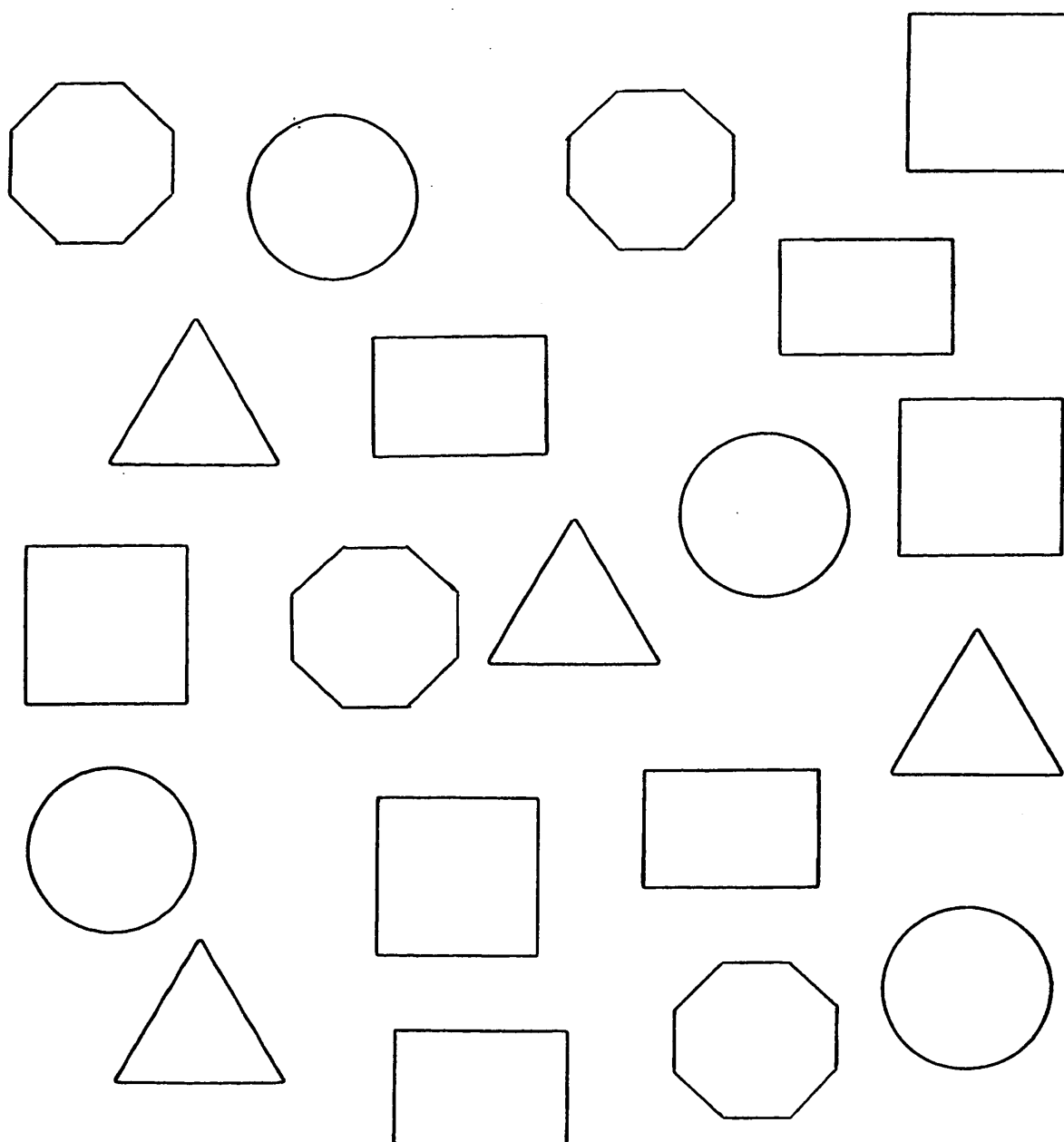
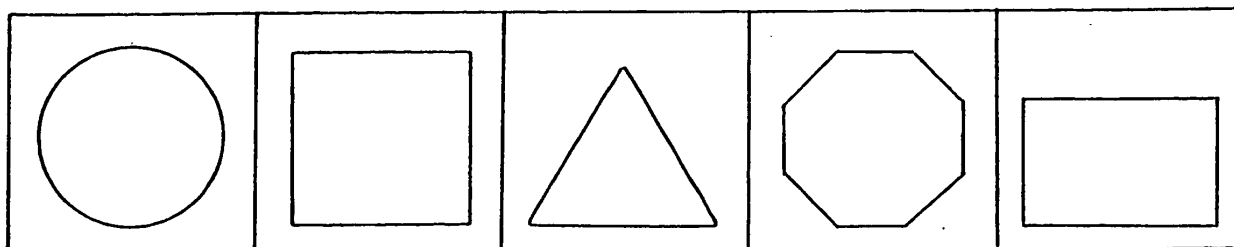

OBIETTIVO: saper classificare interno e bordo delle forme

ATTIVITÀ: il bambino colora l'interno delle forme e il bordo dei segnali

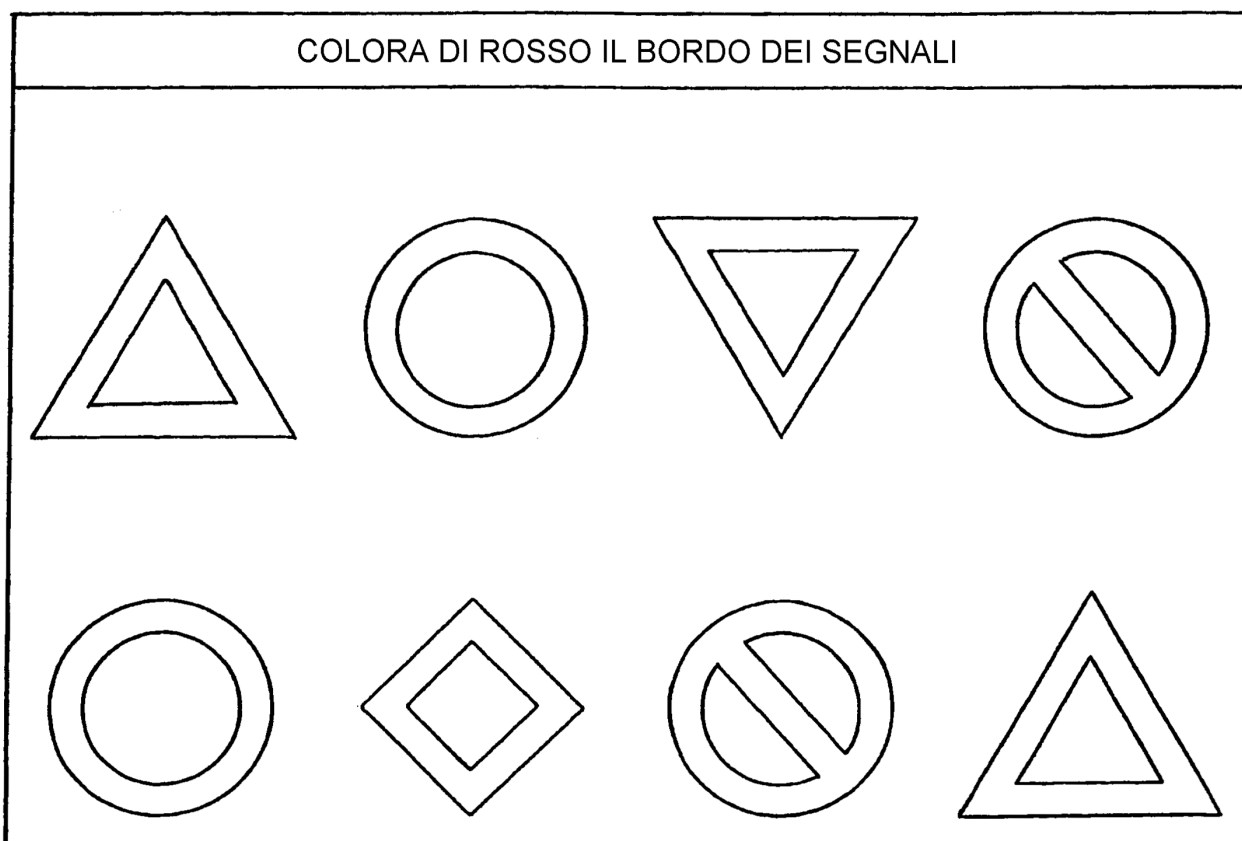
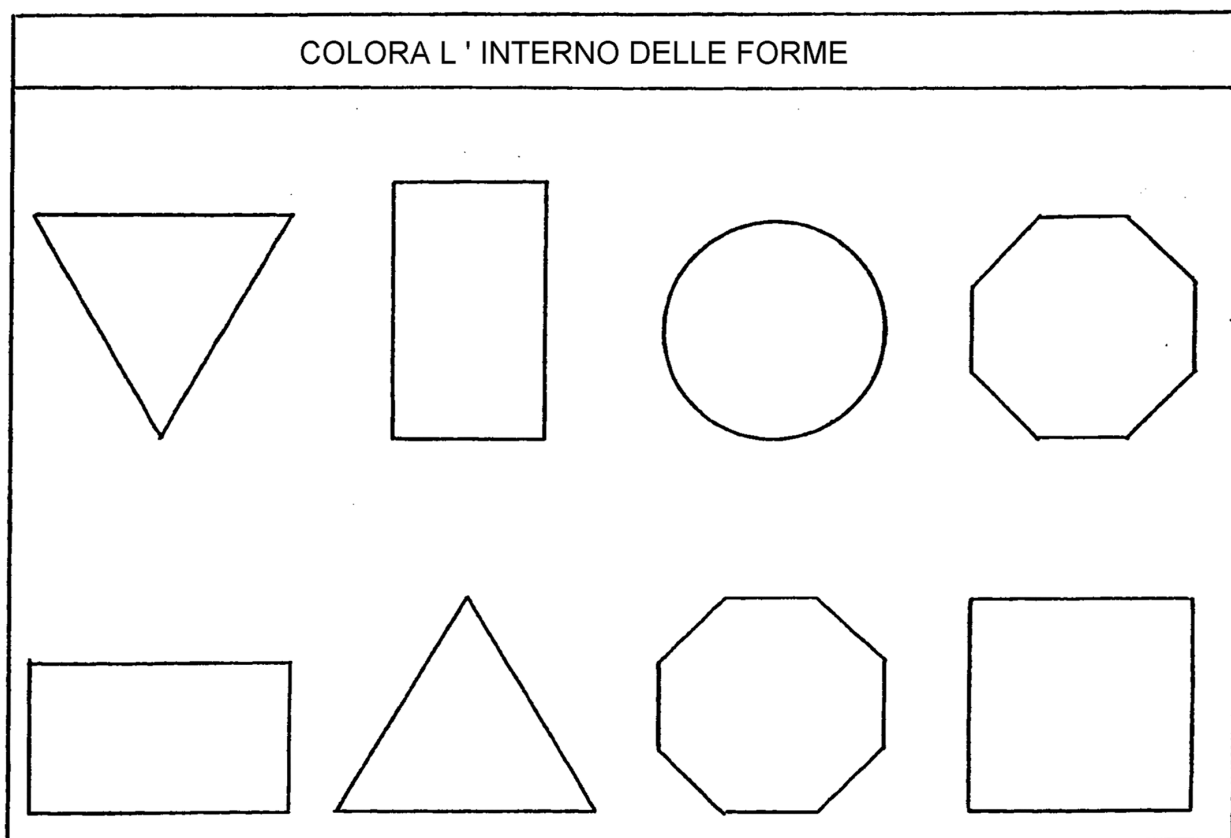

OBIETTIVO: saper realizzare strutture ritmiche con le forme

ATTIVITÀ: il bambino completa disegnando le forme che mancano, poi le colora come a pag.4

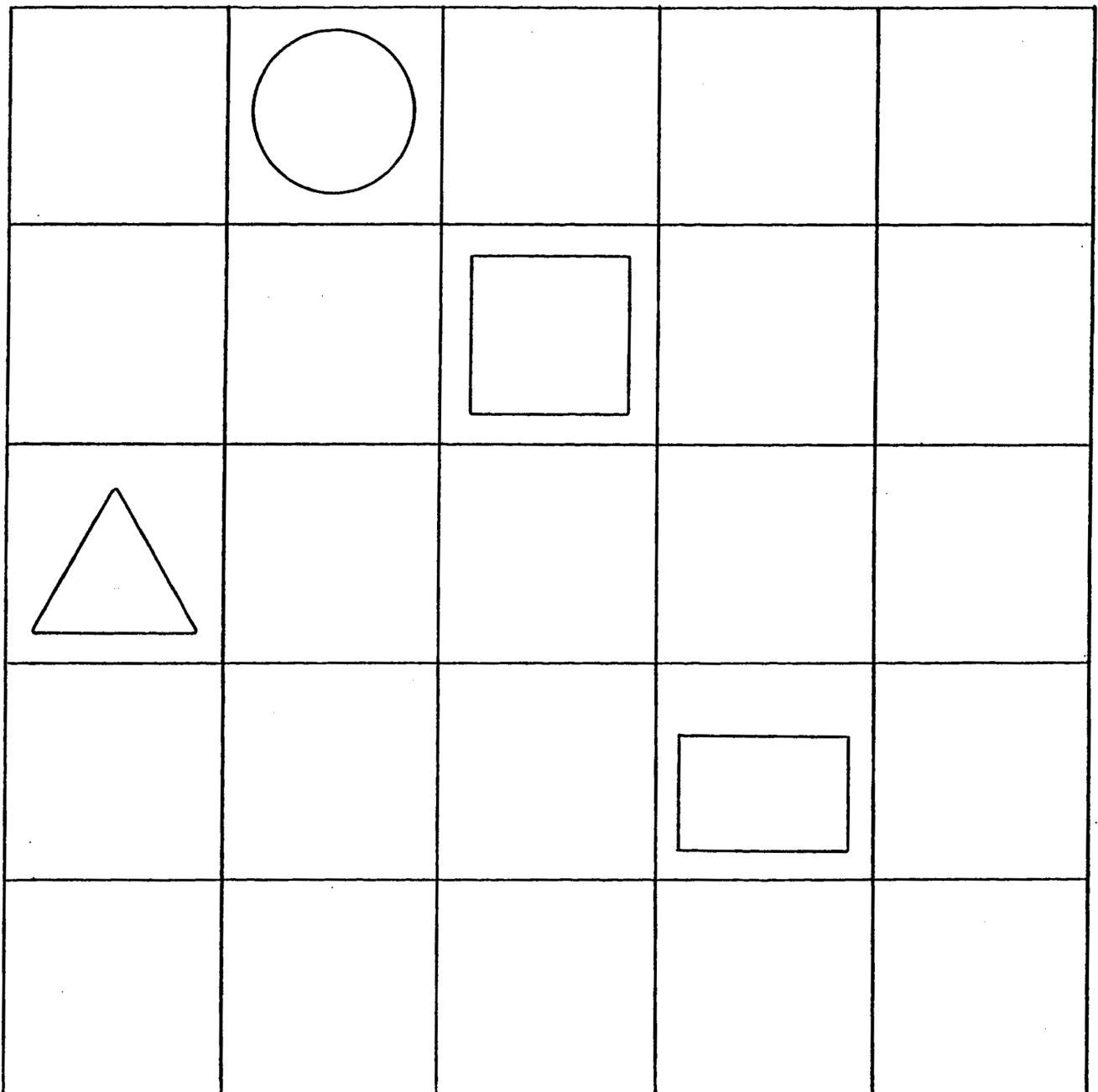
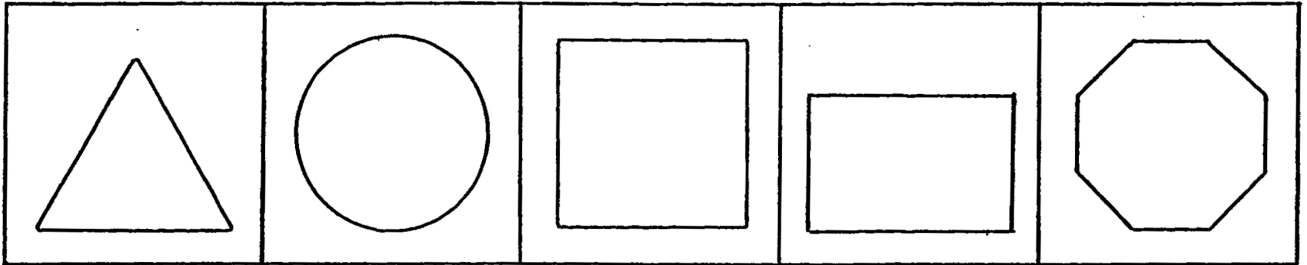

OBIETTIVO: coordinazione visivo-motoria

ATTIVITÀ: il bambino ripassa le linee e le parole tratteggiate, poi colora le forme come a pag.4

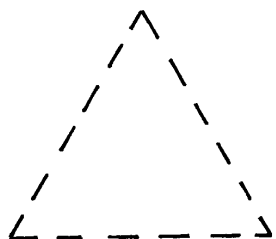

TRIANGOLARE

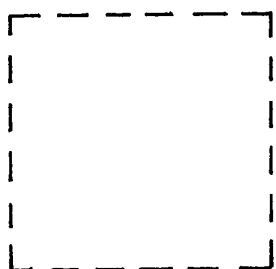

QUADRATA

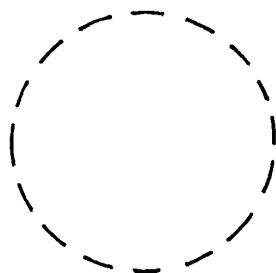

ROTONDA



RETTANGOLARE

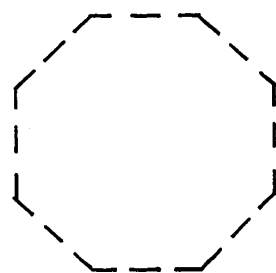

OTTAGONALE

LA STRADA

OBIETTIVO: saper riconoscere e classificare gli utenti della strada pedoni conducenti

ATTIVITÀ: il bambino colora la strada e i pedoni

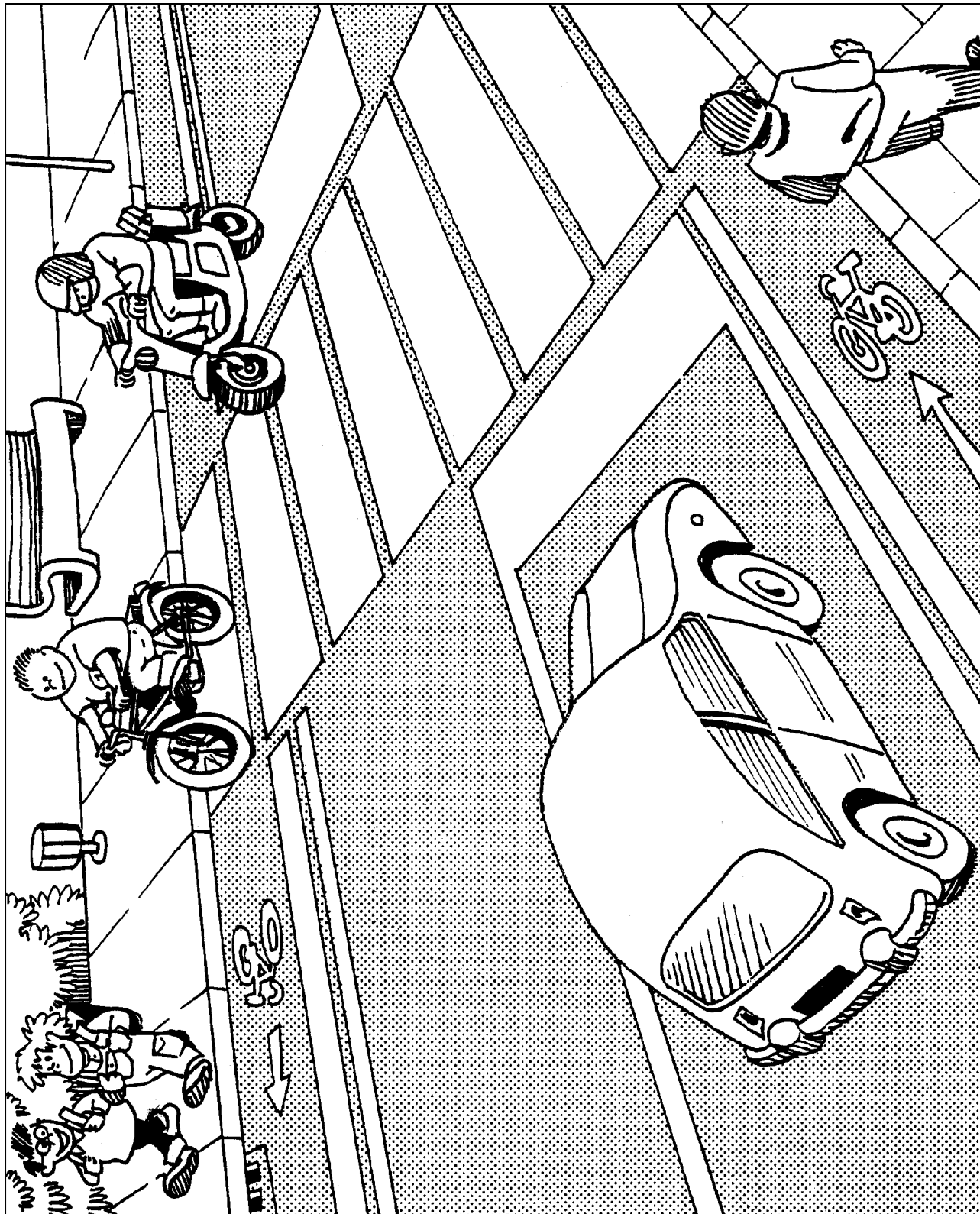

ATTIVITÀ: il bambino individua le azioni effettuate dai soggetti e verbalizza la situazione rispondendo alle domande: Chi? Che cosa fa? Cosa succede? Dove si può giocare?...

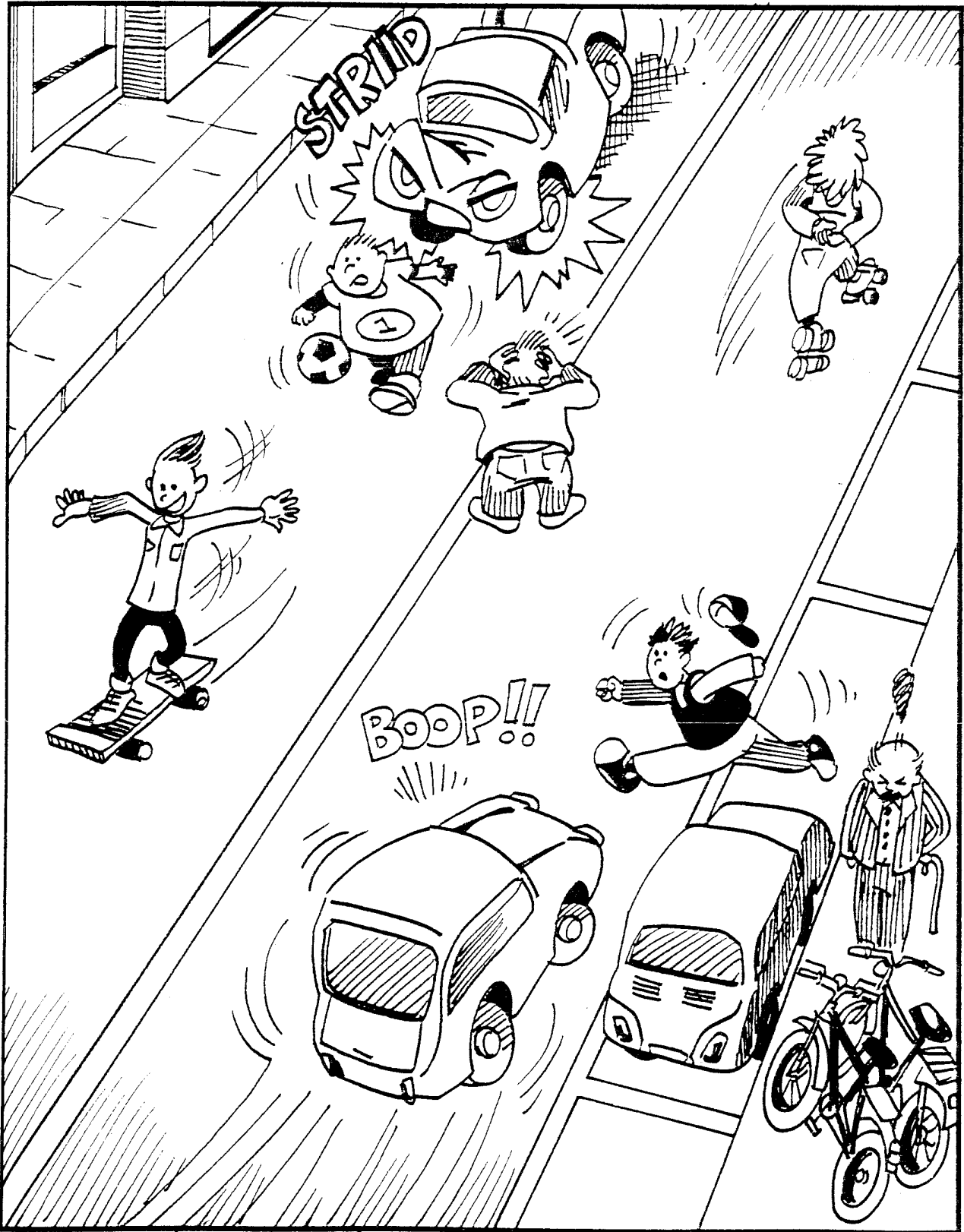

USO DEL MARCIAPIEDE: DESTRA E SINISTRA

OBIETTIVO: comportamento del pedone - uso del marciapiede

ATTIVITÀ: il bambino individua i pedoni che camminano sul marciapiede destro e li colora, ritagliando le figure che si trovano a pag.11

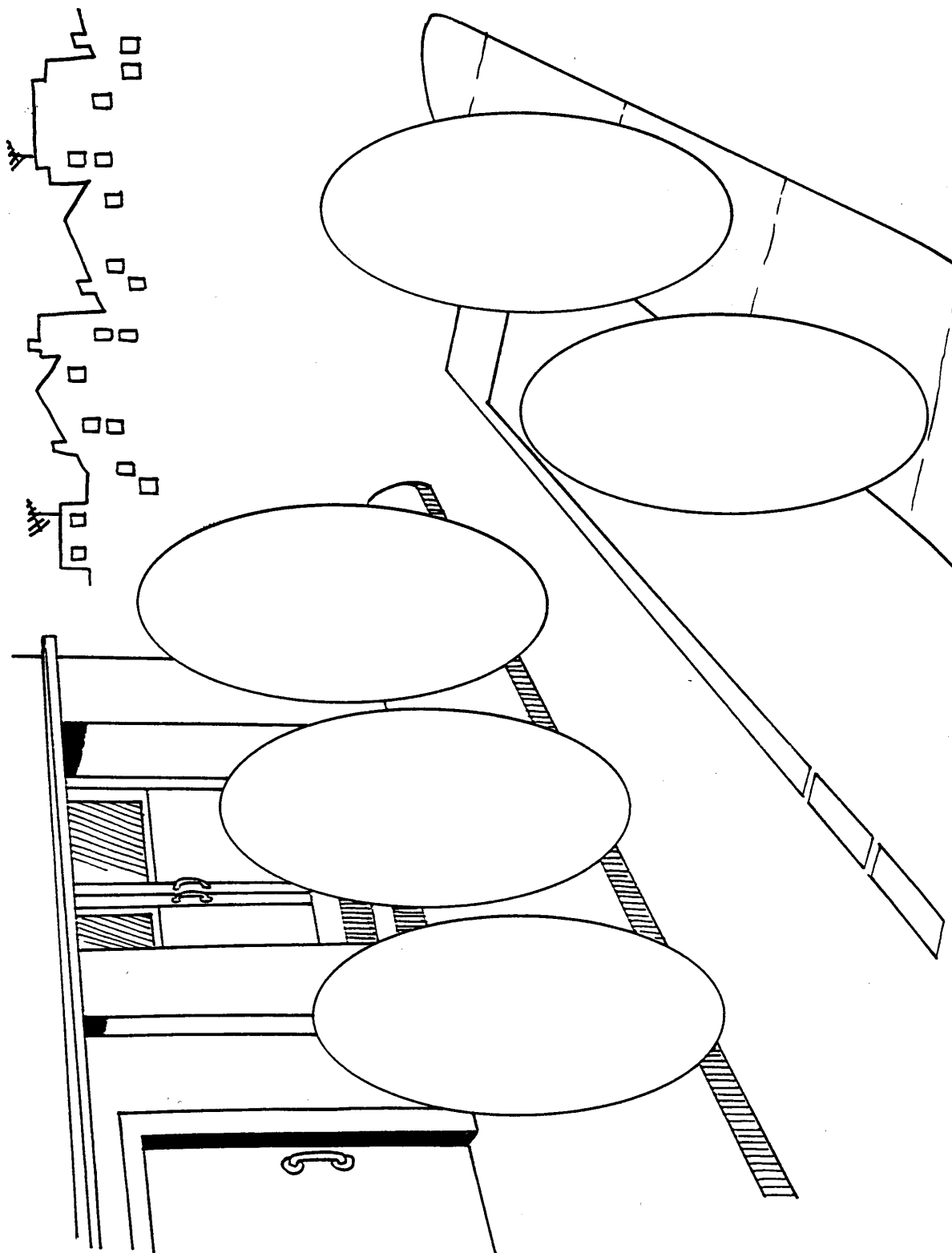

**COLORA, RITAGLIA ED INCOLLA NELL'APPOSITA
SCHEDA A PAGINA 10**

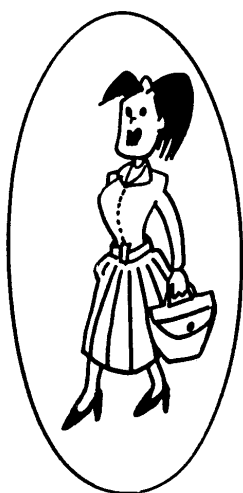

IL PEDONE

ATTIVITÀ: il bambino colora

GASTONE IL PEDONE



OBIETTIVO: comprensione e interiorizzazione delle norme di circolazione del pedone

ATTIVITÀ: il bambino individua il comportamento corretto e colora il pedone che rispetta la norma di circolazione.

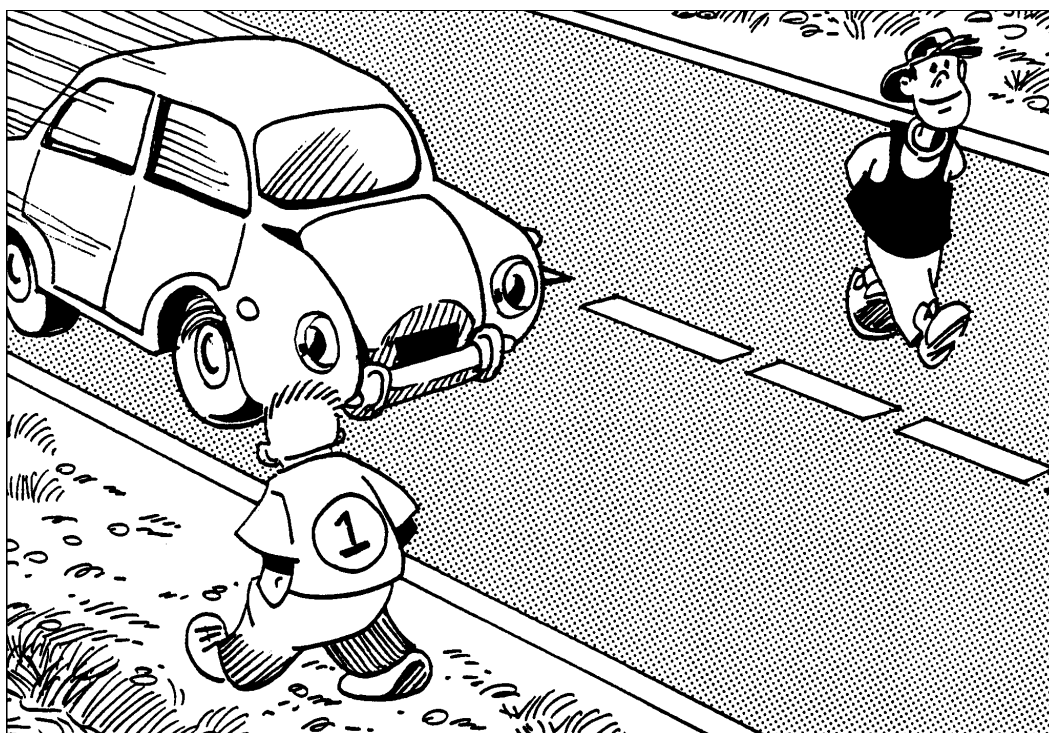

ATTIVITÀ: il bambino cancella con un segno il comportamento errato poi colora la persona che rispetta la norma camminando sul marciapiede

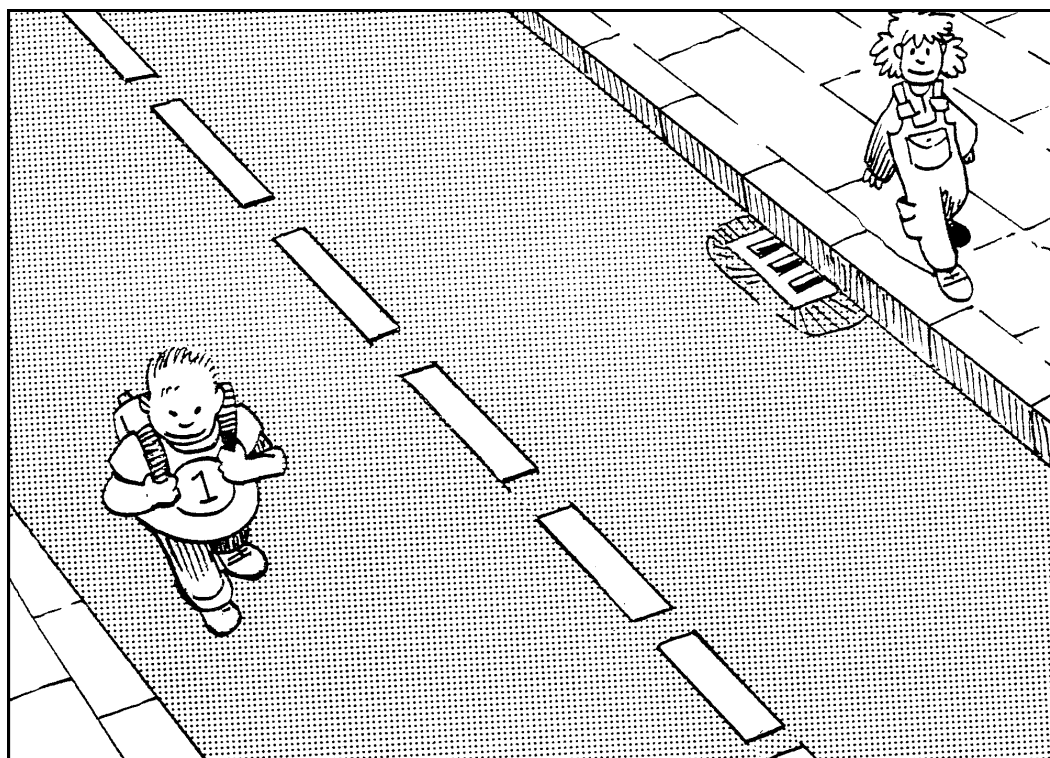

ATTRAVERSAMENTO DELLA STRADA

OBIETTIVO: comprensione delle norme di circolazione - uso delle strisce pedonali

ATTIVITÀ: il bambino dipinge la scena rispettando i colori reali

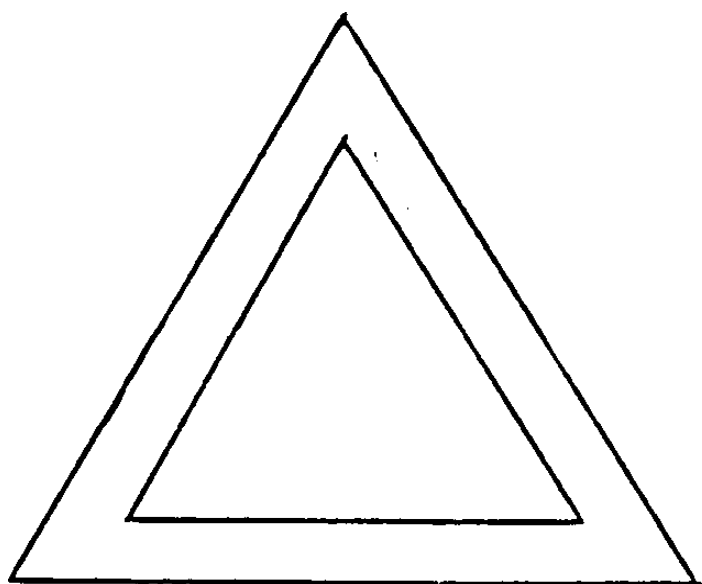
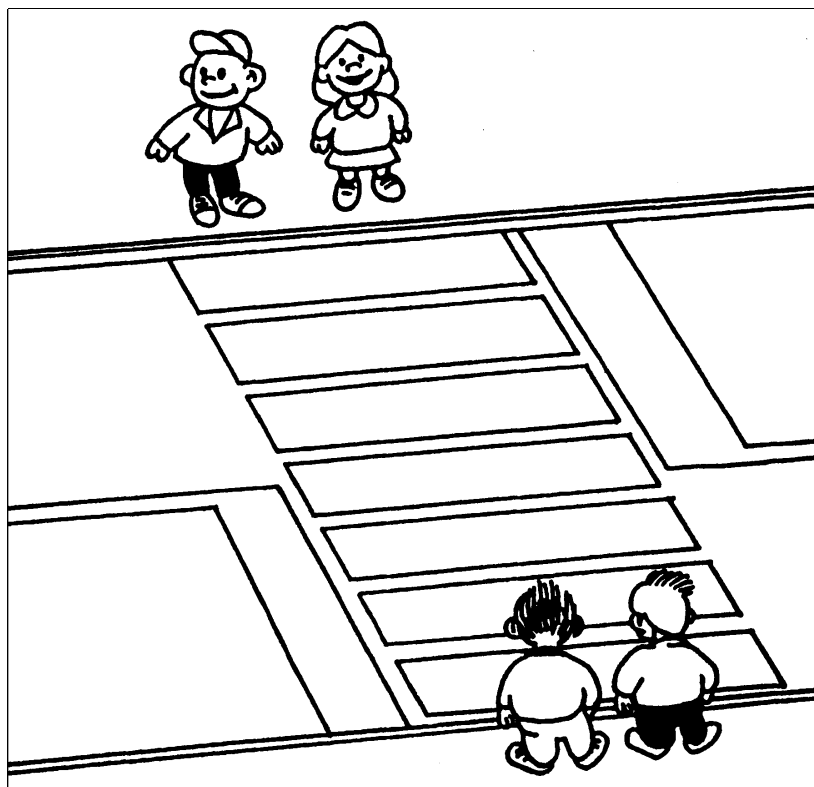

ATTIVITÀ: il bambino ritaglia il triangolo, compone il segnale di attraversamento e poi colora il bordo

OBIETTIVO: comportamento per la strada - attraversamento della carreggiata

ATTIVITÀ: il bambino cancella con una crocetta il comportamento errato e colora il comportamento corretto

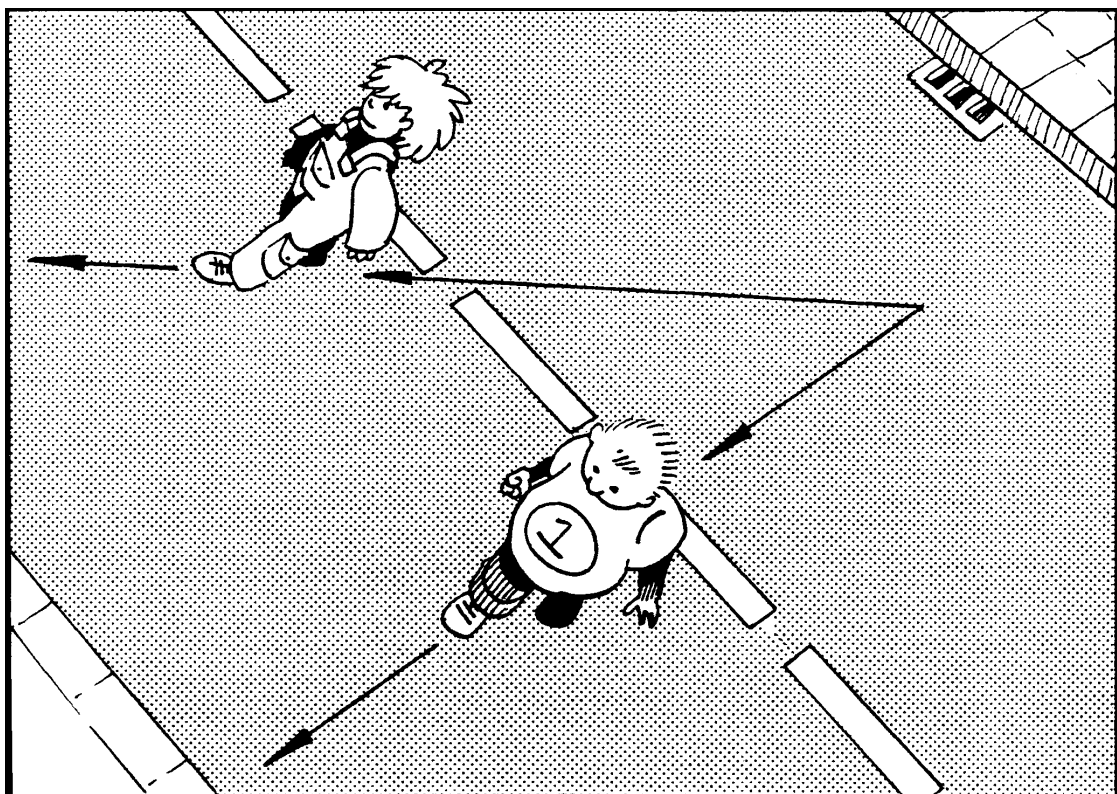
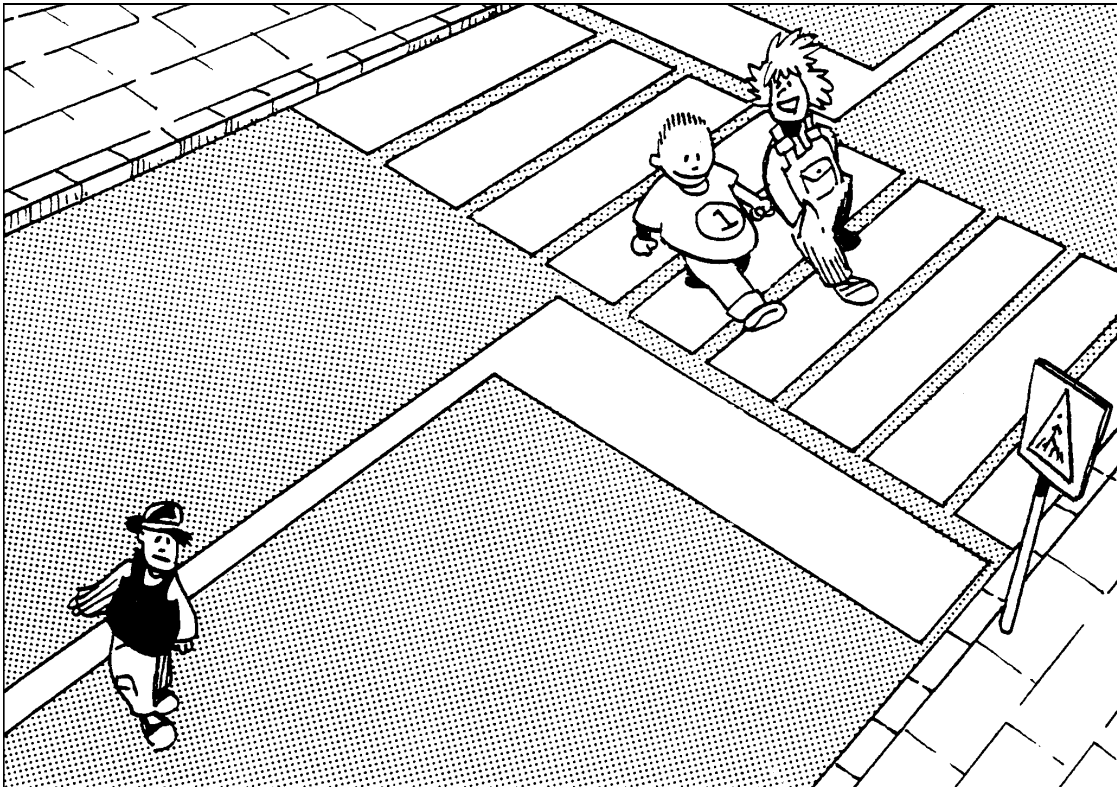

IL SEMAFORO PEDONALE

OBIETTIVO: saper associare il colore del semaforo al simbolo scritto

ATTIVITÀ: il bambino ripassa i tratteggi e colora le figure evidenziate con i rispettivi colori rosso, giallo e verde.

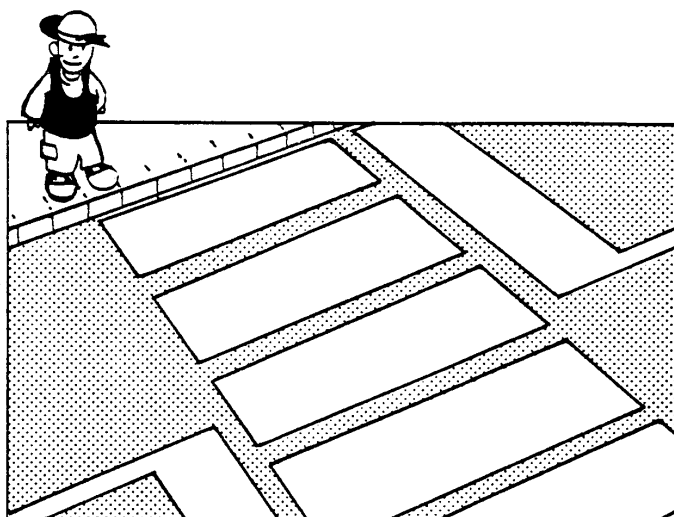
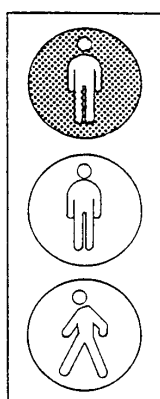
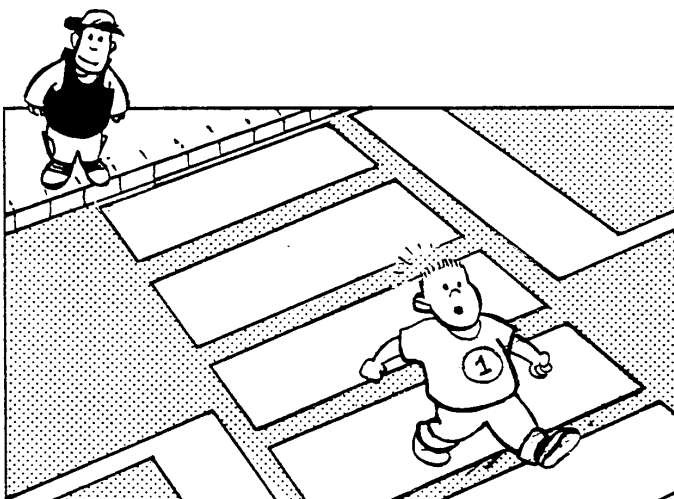
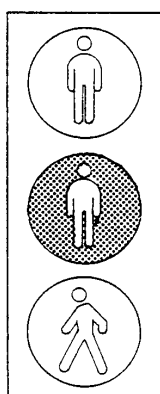
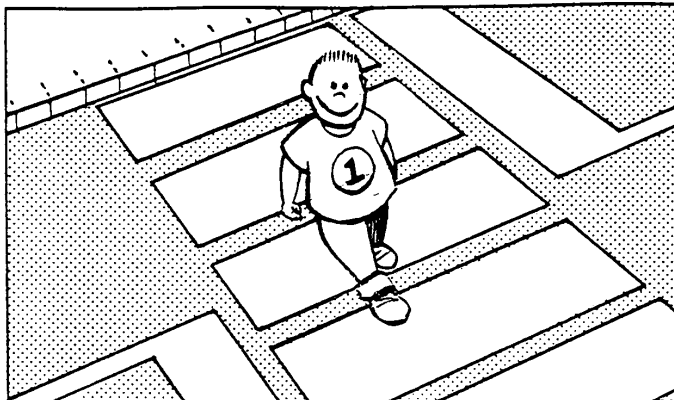
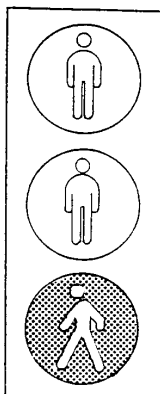

IL VIGILE

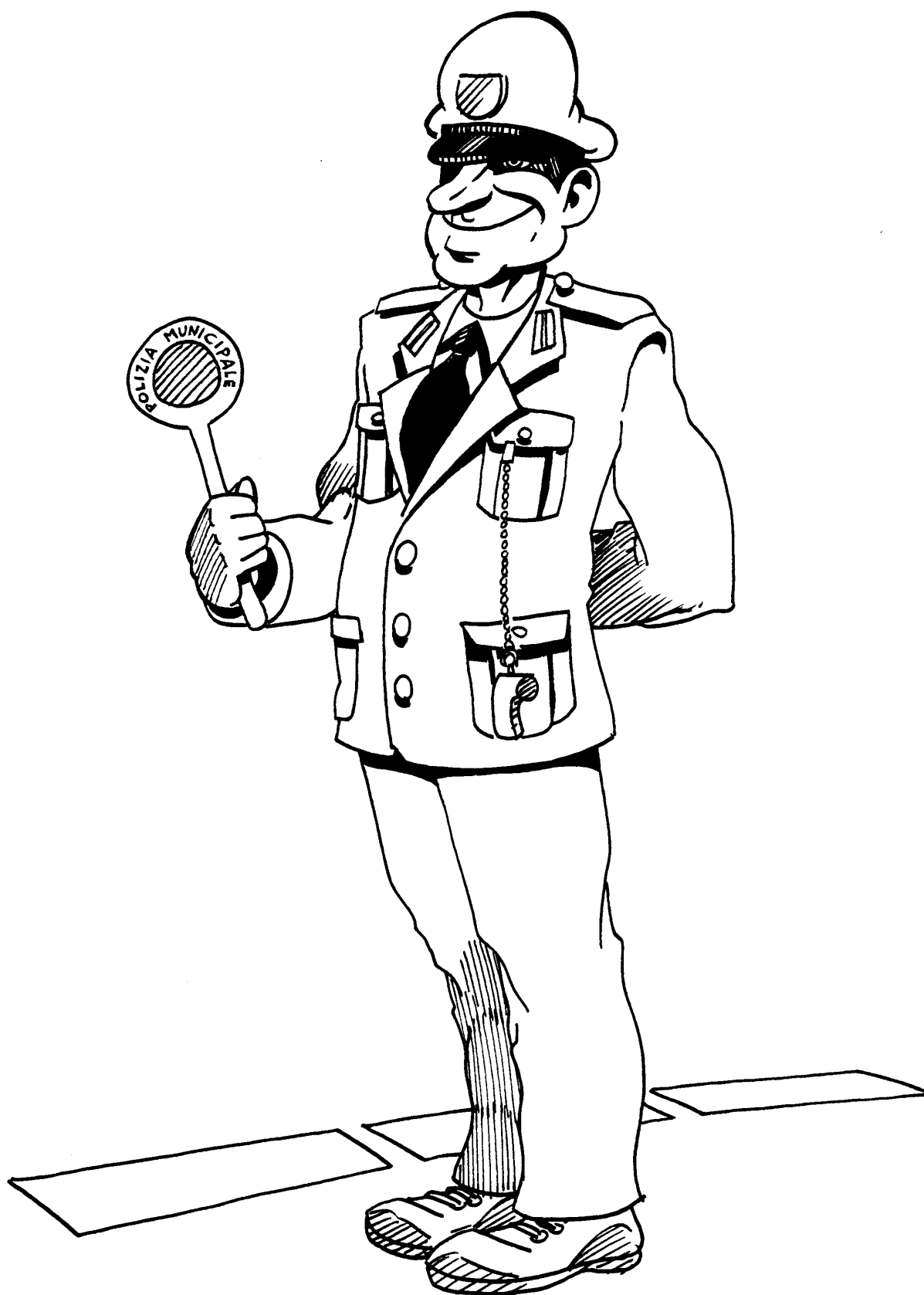

OBIETTIVO: conoscenza delle persone che favoriscono la circolazione
ATTIVITÀ: il bambino colora il vigile

I GESTI DEL VIGILE

OBIETTIVO: saper abbinare i gesti del vigile al colore del semaforo

ATTIVITÀ: il bambino colora il semaforo in base al gesto del vigile

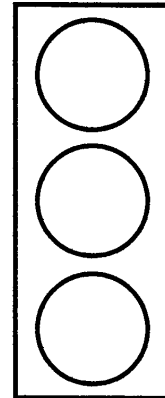
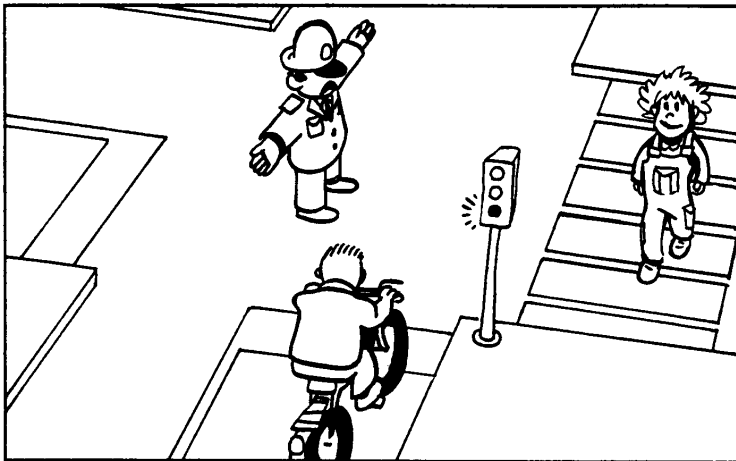

VERDE

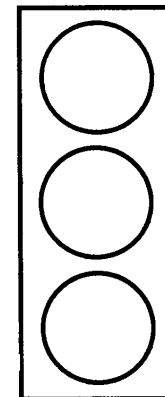
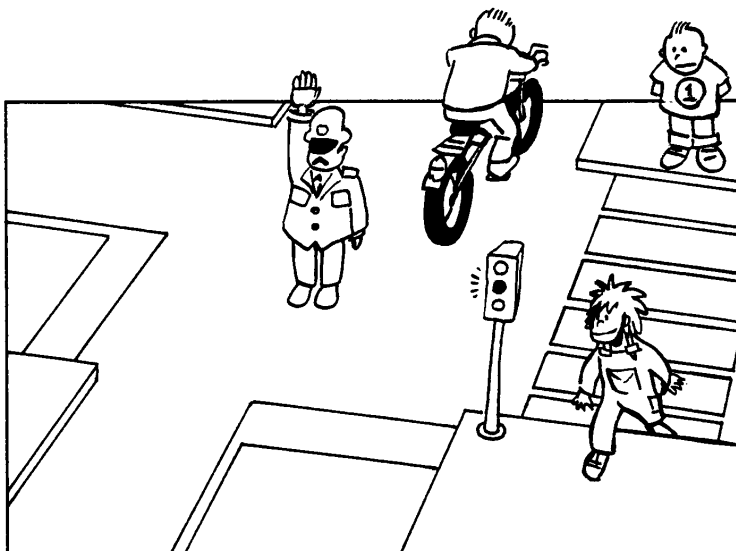

GIALLO

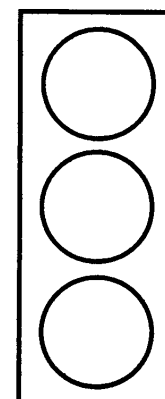
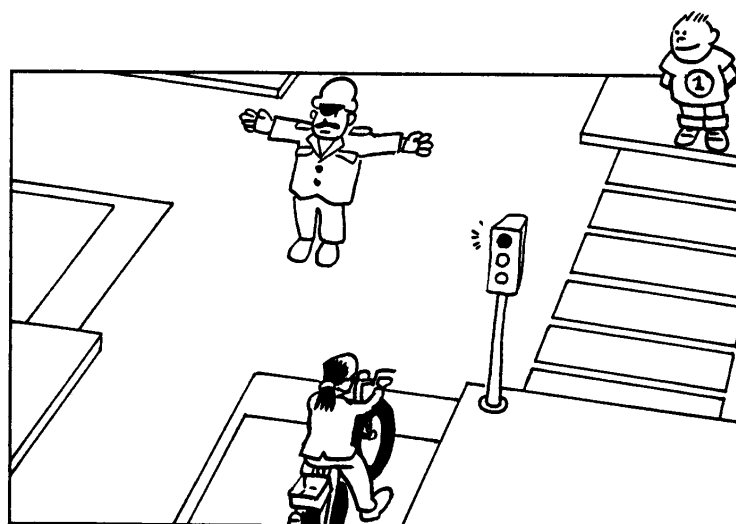

ROSSO

CONOSCI I TUOI SEGNALI

OBIETTIVO: saper riconoscere, classificare, associare alcuni segnali

PRECEDENZA



PERICOLO



OBBLIGO

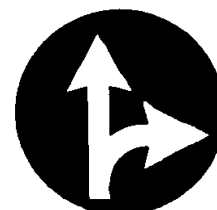

DIVIETO

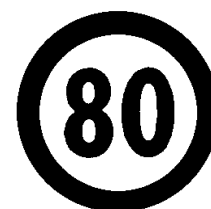

INDICAZIONE



ATTIVITÀ: a pag. 25 il bambino ricerca, ritaglia, incolla e colora i segnali di PRECEDENZA

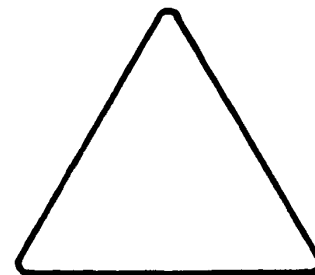
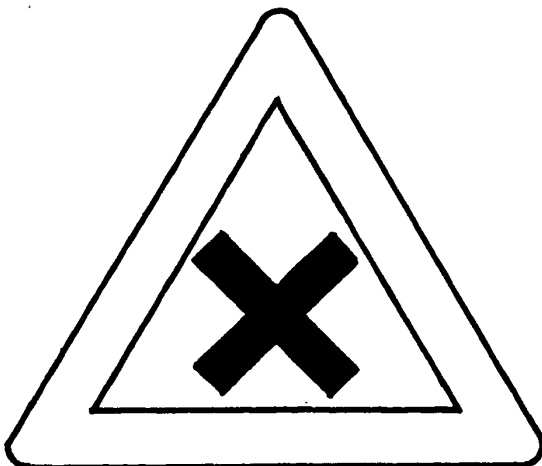
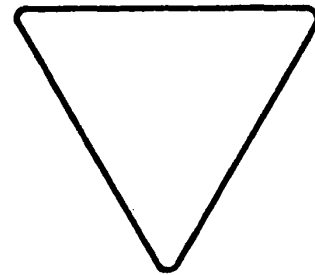
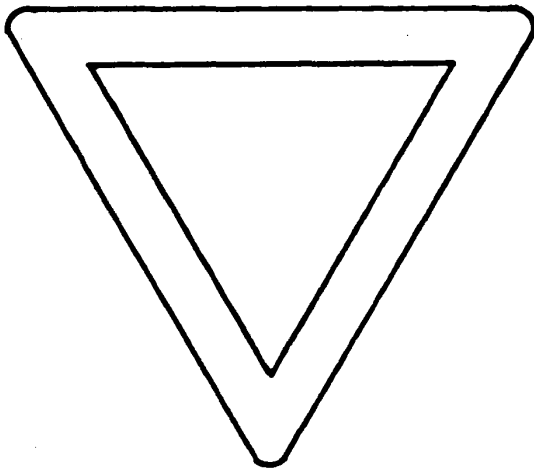
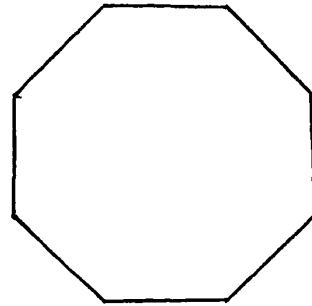
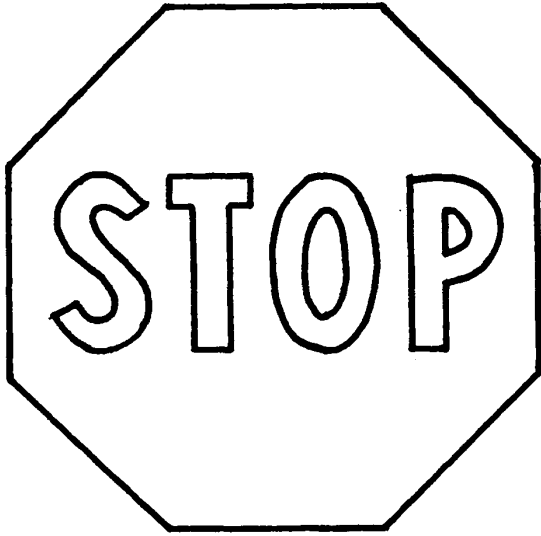

ATTIVITÀ: a pag. 25 il bambino ricerca, ritaglia, incolla e colora i segnali di PERICOLO

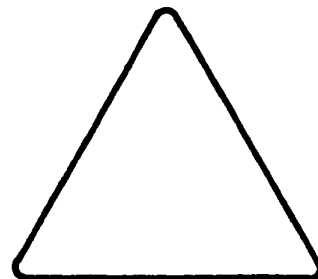
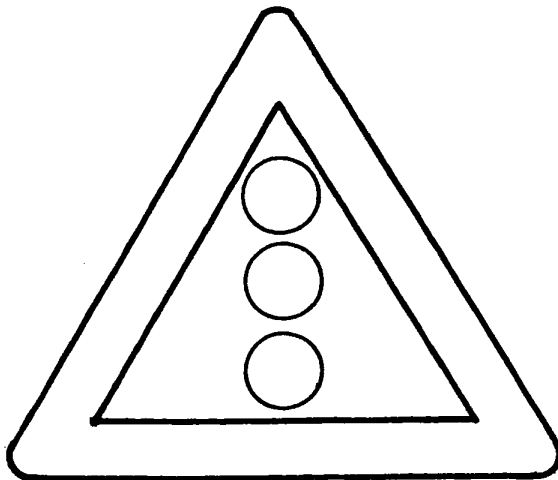
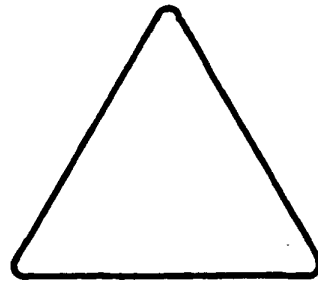
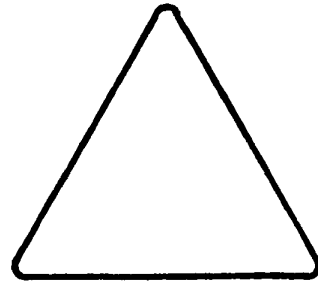
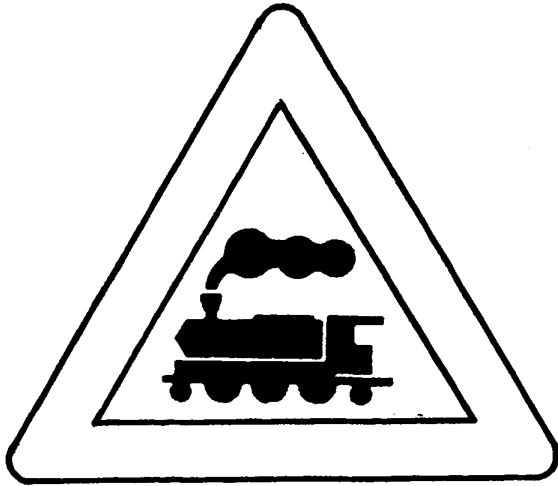

ATTIVITÀ: a pag. 25 il bambino ricerca, ritaglia, incolla e colora i segnali di OBBLIGO

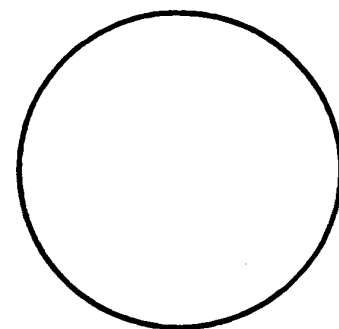
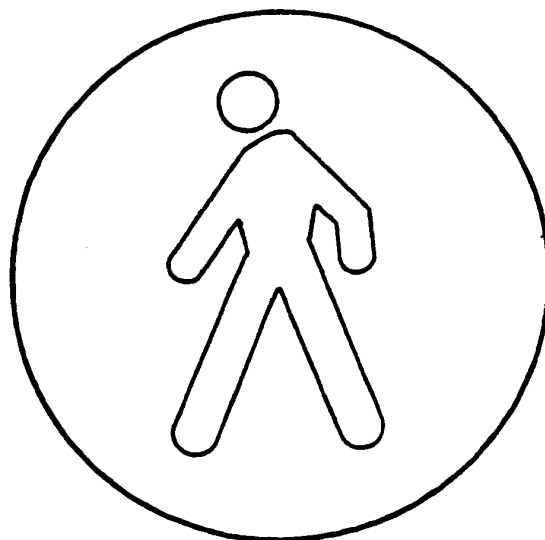
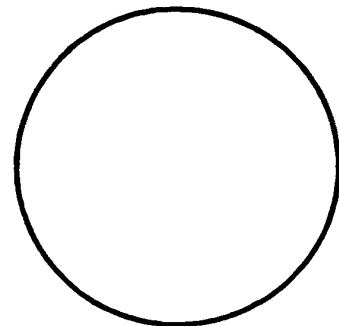
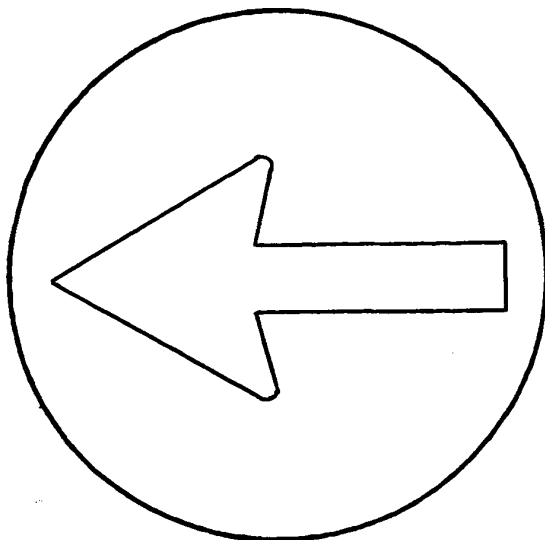
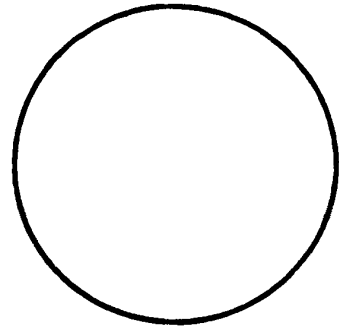
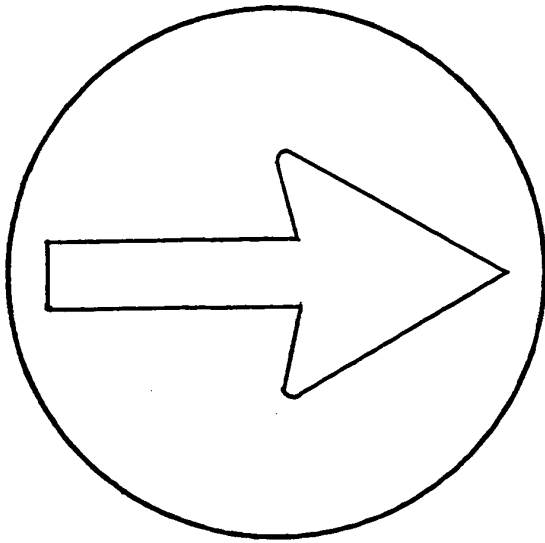

ATTIVITÀ: a pag. 25 il bambino ricerca, ritaglia, incolla e colora i segnali di DIVIETO

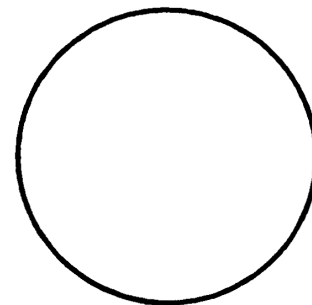
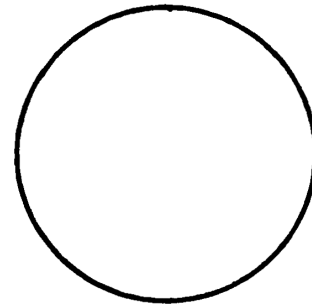
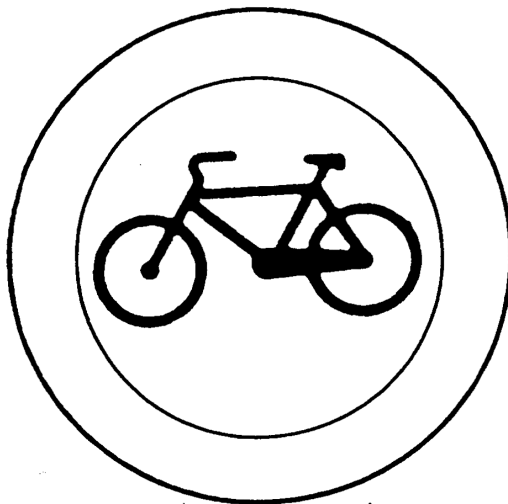
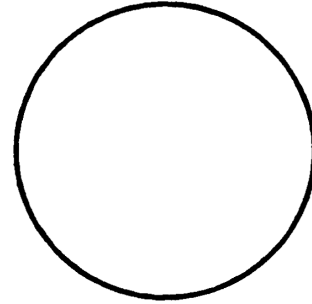

ATTIVITÀ: a pag. 25 il bambino ricerca, ritaglia, incolla e colora i segnali di INDICAZIONE

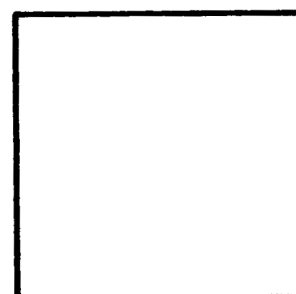
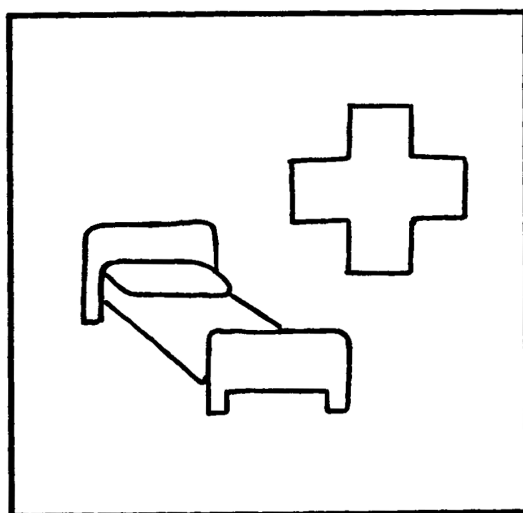
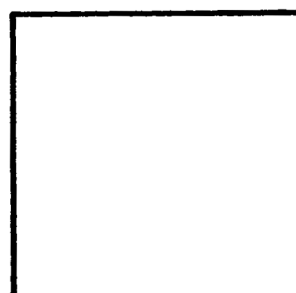
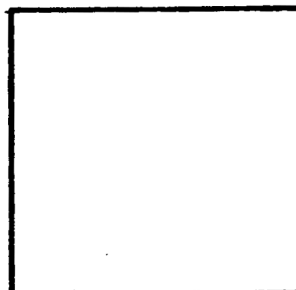
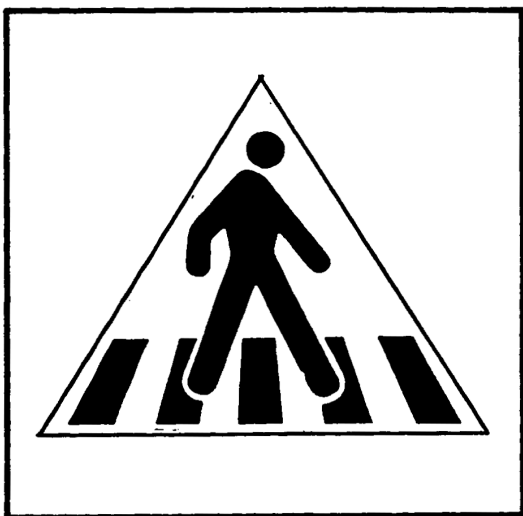

COLORA, RITAGLIA ED INCOLLA NELLE APPOSITE SCHEDE

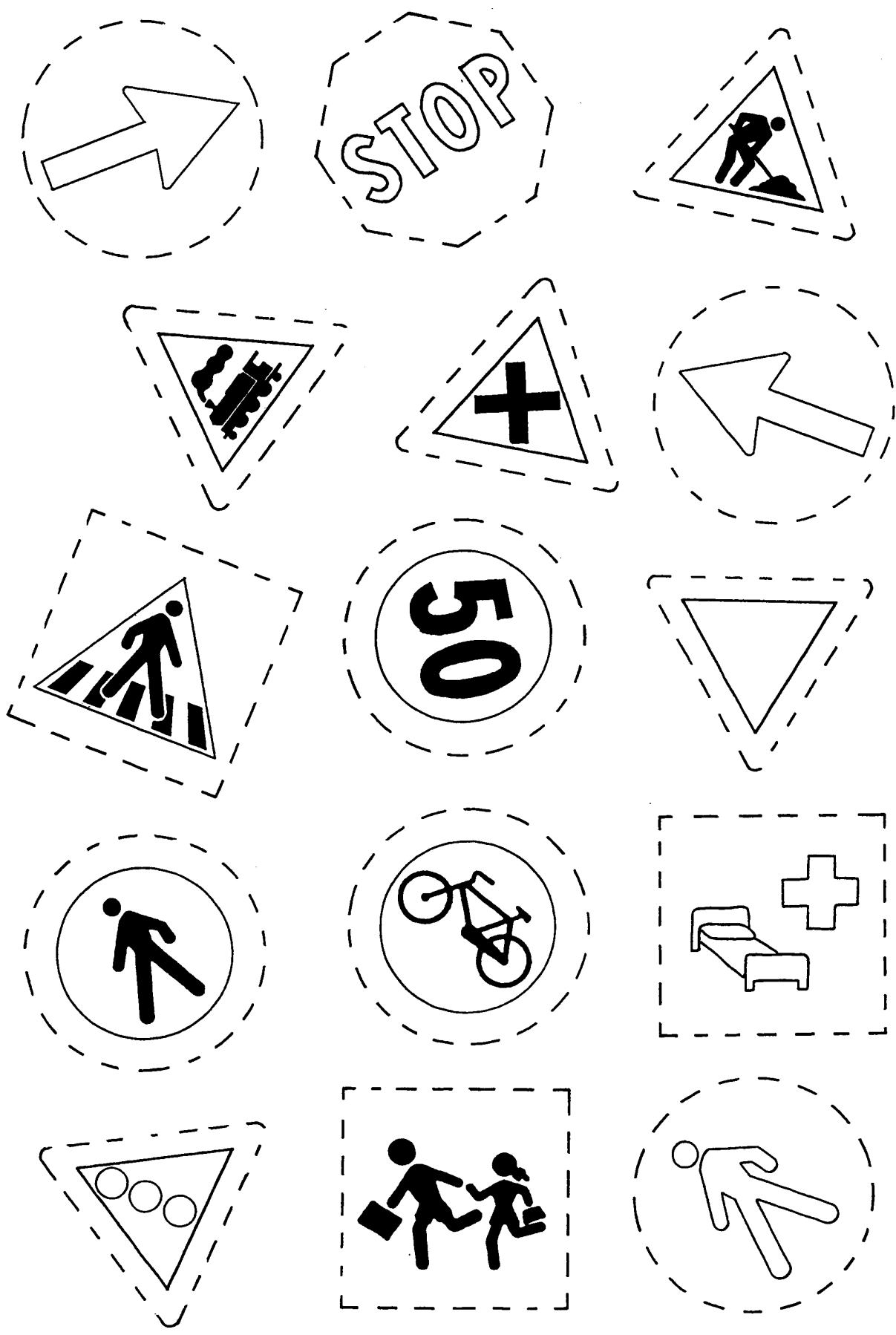

AVVISO AI GENITORI

Il giorno _____ alle ore _____,

con la collaborazione del Comando di Polizia

Municipale di _____ 1

si svolgerà una esercitazione pratica di

EDUCAZIONE ALLA SICUREZZA STRADALE

dei bambini della Scuola Materna _____

2



1 Comune
2 nome della scuola

SICUREZZA STRADALE NON E' UNO SLOGAN E' VITA

Progetto Educazione alla Sicurezza Stradale: lavoro sviluppatosi, in diversi anni, con la collaborazione dei Circoli Didattici di Salzano e di Mira; della Polizia Municipale di Salzano e di Spinea e dell'esperienza pratica di insegnanti di scuole elementari.



Associazione Donatori Midollo Osseo



Associazione Italiana Donatori Organi



Associazione Volontari Italiani del Sangue

INSIEME PER LA VITA